

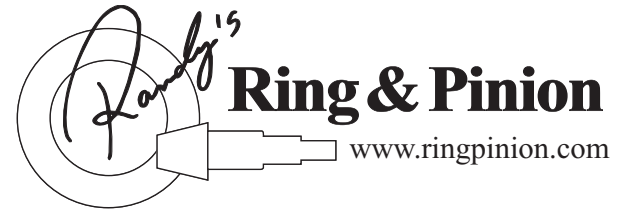



**1-800-347-1188**



**INSTRUCTIONS FOR PINION DEPTH SETTING KIT**

### Pinion Depth Setting Tool (TSLD02)

- 1) Measure the pinion head thickness (PHT) before install and write that number down for later reference along with the “Master Housing Dimension” (MHD) obtained from the OEM Gear Section of the instruction manual. Subtract PHT from MHD for pinion depth (PD).
- 2) Calibrate the tool according to the instruction manual. Write down that number (calibrated depth).
- 3) Set up the tool (dial indicator) inside the housing and take your indicator reading, then subtract that number from the calibrated depth. This new number is the MPD (measured pinion depth).
- 4) Always subtract PD from MPD regardless of which number is smaller. If the result is negative, subtract that amount from the shim pack.

### Example from a D44 done in our shop:

4.312” . . . . Master Housing Dimension (MHD), obtained from OEM gear section of manual.

1.655” . . . . Measured pinion head thickness (PHT). Remember step #1.

2.657 . . . . Pinion Depth (PD)

3.375” . . . . Calibrated tool depth from instruction manual, remember step #2.

0.676” . . . . Indicator reading from step # 3.

2.699” . . . . Measured pinion depth (MPD)

2.699” . . . . MPD

2.657” . . . . PD

0.042” . . . . Difference (use this amount of shims)

**NOTE:** Be sure that the short pointer (small dial) is in the “zero” position.

- 6) Loosen the indicator bezel lock screw and with the calibration tube in place, make the final adjustment by rotating the dial face until the zero aligns with the pointer. Tighten the indicator bezel lock screw. Your Pinion Depth Checker is now set for the calibrated depth of exactly 3.375” (Or 1.900” for the Ford 9” or 2.500” for the intermediate differentials). **This is the CALIBRATED DEPTH.**

**FIGURE 1: Dial Indicator Calibration**

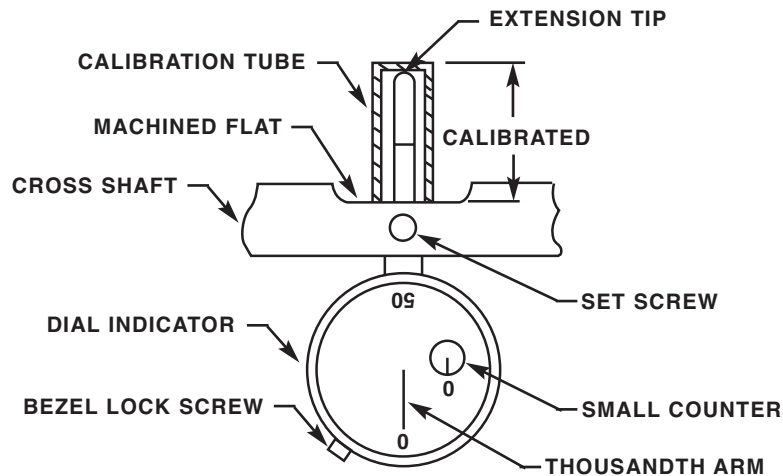

**GENERAL MOTORS**

- 10 Bolt 7.2 (3.693 MHD)
- 10 Bolt 7.5 (3.787 MHD)
- 10 Bolt 8.2 x 25 Spline Pinion (4.175 MHD)
- 10 Bolt 8.2 x 27 Spline Pinion (4.175 MHD)
- 10 Bolt 8.2 x Thin 55-64 Vette (4.125 MHD)
- 10 Bolt 8.5 x 30 Spline (4.262 MHD)
- 10 Bolt 8.5 x 27 Spline (4.262 MHD)
- 12 Bolt 8.875 x 1.438 Pinion Dia. (4.556 MHD)
- 12 Bolt 8.875 x 1.625 Pinion Dia. (4.670 MHD)
- 12 Bolt 9.300 (4.620 MHD)

**FORD**

- 6.625 (3.500 MHD)
- 7.5 (4.040 MHD)
- 8.0 (4.000 MHD)
- 8.8 (4.415 MHD)
- 9.0 (4.375 MHD)

**AMC**

- 8 Bolt 8.875 (4.500 MHD)

**DANA**

- Dana 30 (3.625 MHD)
- Dana 36 (3.931 MHD)
- Dana 44 (4.312 MHD)
- Dana 50 (4.616 MHD)
- Dana 60 (5.000 MHD)
- Dana 70 (5.375 MHD)

**CHRYSLER**

- 10 Bolt 8.250 (4.124 MHD)
- 12 Bolt 8.750 x 1.750 Pinion Stem (4.350 MHD)
- 12 Bolt 8.750 x 1.875 Pinion Stem (4.344 MHD)
- 12 Bolt 9.250 (4.625 MHD)

**DISCLAIMER**

No warranty, expressed or implied is provided for the actual ring and pinion adjustment or the in-service performance of equipment that has been set with the instructions and parts contained in our kit. Pinion depth settings are the responsibility of the gear manufacturers. The accuracy of the adjustments are the responsibility of the user.

**NOTE:** All gear sets should be installed per manufacturer's instructions or recommendations. We recommend a final check of the tooth contact pattern to be sure no mistakes have been made during assembly.

**MEASURING PINION DEPTH (1-2-3 BLOCK METHOD)**

This method will allow you to check and adjust pinion depth without pressing the pinion bearing on and off of the pinion multiple times.

- 1) Carefully remove any sharp edges or burrs from the carrier bearing housing and caps to avoid any inaccuracy or marring of the hubs.
- 2) Place the pinion bearing in the pinion race and place the 1-2-3 block directly on top of the pinion bearing. Then place the appropriate target plate on top of the 1-2-3 block.
- 3) Select the appropriate hubs and lightly oil the bores to prevent galling and carefully insert the Cross Shaft into the Hubs. Place this assembly in the case and tighten main cap bolts to 25 ft.-lbs.

- 4) Slide the Indicator and Cross Shaft as close as possible to pinion gear, minimizing any overhang of the Target Plate. Be sure to retract the indicator plunger shaft just enough to clear the Target Plate to prevent bending the indicator.
- 5) Make sure the Indicator shaft end is seated on the target plate and note the reading on the dial. Multiply the small counter number by 0.100" and add the thousandths pointer reading to get you INDICATOR READING. Subtract your INDICATOR READING from the CALIBRATED DEPTH (3.375 for long extension, 2.500 for the intermediate & 1.900 for the short) and then add the height of the block to obtain your MEASURED HOUSING DEPTH. Subtract the MASTER HOUSING DIMENSION from the MEASURED HOUSING DEPTH to get the amount of shim required.

**Example:** If the reading on the indicator is 0.680" (6 complete revolutions plus reading), subtracting from 3.375 would equal 2.695". Add 2" for the thickness of the 1-2-3 block and this equals 4.695. This is the MEASURED HOUSING DEPTH. Subtracting 4.670 (The master housing dimension for this example) equals 0.025" shim.

**FIGURE 5: Set-Up**

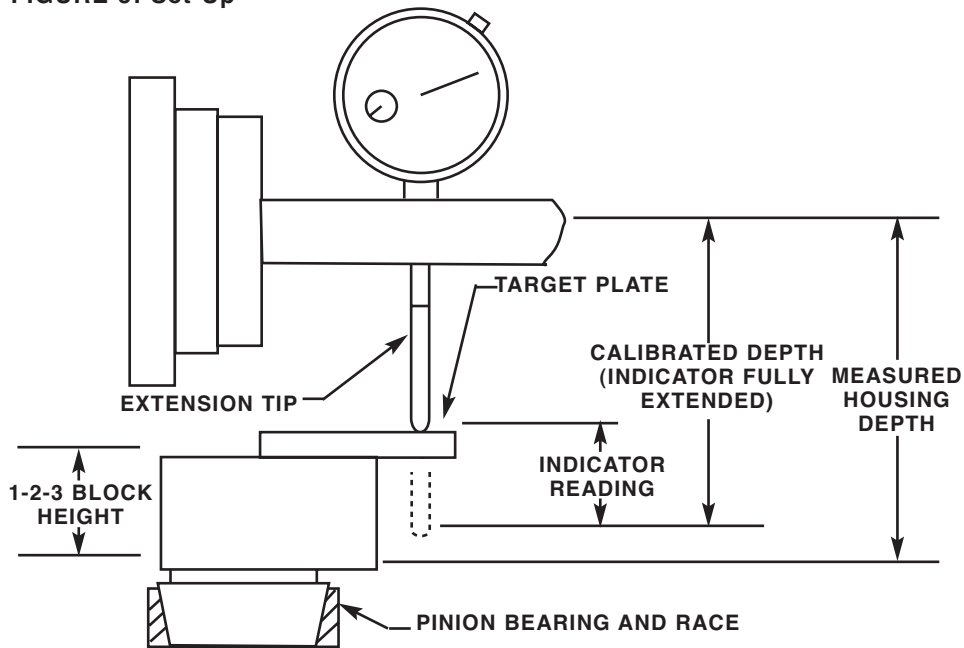

## INTRODUCTION

This kit is equipped to set-up the following, with the recommended target plate and indicator extensions to be used in parenthesis:

- **GM 10 Bolt** (Long Extension and Magnetic Target Plate)
- **GM 12 Bolt** (Long Extension and Magnetic Target Plate)
- **1972 and later GM Corporate 10 Bolt** (Long Extension and Magnetic Target Plate)
- **1982 to present GM 7.5" 10 Bolt** (Intermediate Extension and Magnetic Target Plate)
- **Dana 30** (Intermediate Extension and Magnetic Target Plate)
- **Dana 36** (Intermediate Extension and Magnetic Target Plate)
- **Corvette Dana 44** (Long Extension and Magnetic Target Plate)
- **Dana 60** (Long Extension and Magnetic Target Plate)
- **Ford 9"** (Short Extension and Non-Magnetic Target Plate)
- **Ford 8.8"** (Long/Intermediate Extension depending on gear set and Magnetic Target Plate)
- **8 3/4" Chrysler** (Long Extension and Magnetic Target Plate)
- **57-64 Olds & Pontiac** (Long Extension and Magnetic Target Plate)
- **AMC 8-Bolt** (Long Extension and Magnetic Target Plate)

## CALIBRATION

**NOTE:** Each calibration tube is calibrated and sealed for each application.

- 1) **Important:** Before attempting calibration, carefully wipe all parts clean. Any dirt may prevent a correct calibration.
- 2) Insert the Dial Indicator into the Cross Shaft with the Dial Indicator on the rounded side of the shaft and tip extending thru the flat area on the opposite side. Snug the set screw making sure not to over-tighten.
- 3) Remove the Indicator Extension stored inside the appropriate Calibration Tube and screw the extension tip into the Dial Indicator until snug.
- 4) Hold the Cross Shaft and indicator assembly with the indicator tip pointed up. Slip the calibration tube over the tip and allow the tube to rest on the flat area on the cross shaft.
- 5) The thousandth (long arm) pointer should rotate clockwise slightly (about 0.020") and be pointed approximately straight down, or in the 6 o'clock position. If the pointer does not point straight down, loosen the set screw in the cross shaft and raise or lower the indicator until the needle is pointed straight down with the calibration tube in place. Tighten the set screw until snug (excessive tightening will lock the indicator shaft or permanently bend the housing) and make sure the pointer remains pointing straight down.

## O.E.M. GEAR APPLICATIONS

The list provided on the next page will extend the capabilities of your PINION DEPTH CHECKER KIT. The method described below will allow you to set up rear differentials with gears not inscribed with a pinion depth (i.e., OEM factory gears).

- 1) Measure the thickness of the pinion head with a micrometer (PHT). The thickness is defined as the dimension from the top of the pinion gear to the thrust bearing mounting surface.
- 2) Find the correct application listed below and note the MASTER HOUSING DIMENSION (MHD).
- 3) Subtract the PINION HEAD THICKNESS (PHT) from the MASTER HOUSING DIMENSION (MHD). The number obtained is the PINION DEPTH (PD).
- 4) Now, you can set up your rear differential as described in the section "MEASURING PINION DEPTH".

FIGURE 4: OEM Gear Dimensions

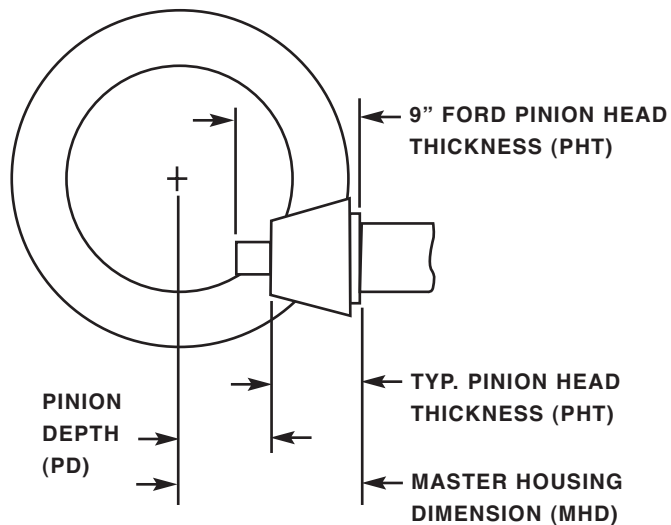

## MEASURING PINION DEPTH

- 1) Carefully remove any sharp edges or burrs from the carrier bearing housing and caps to avoid any inaccuracy or marring of the hubs.
- 2) Make note of the pinion depth inscribed on your pinion gear. If your pinion does not have a depth number on it, go to the "O.E.M. GEAR APPLICATIONS" Section to find the pinion depth.
- 3) Place the pinion in the case with the appropriate bearings and shims.
- 4) Clean the appropriate Target Plate and the face of the pinion gear and then place the Target Plate on the face on the pinion.
- 5) Select the appropriate hubs and lightly oil the bores to prevent galling and carefully insert the Cross Shaft into the Hubs. Place this assembly in the case and tighten main cap bolts to 25 ft.-lbs. See Figure 2 for Hub Applications.

FIGURE 2: Hub Applications

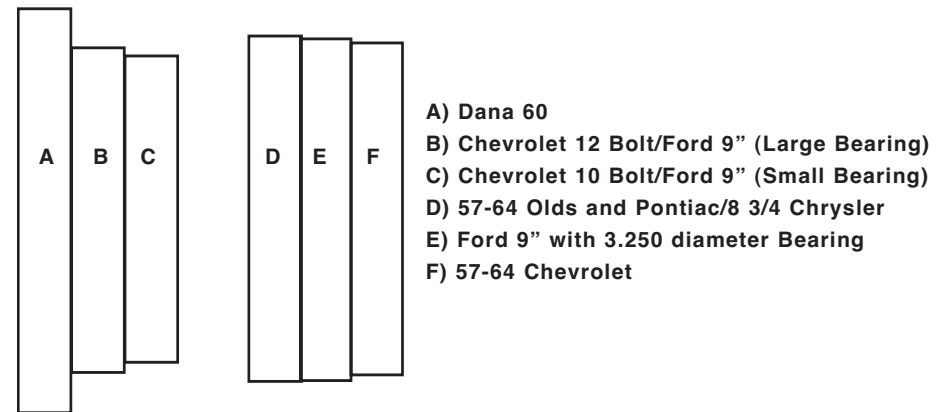

**NOTE:** The "A" diameter has a machined flat to clear the pinion support in the Ford 9" rear ends. Additional relief may be needed for individual applications. When using the "A" diameter in the Dana 60 rear ends, the machined flat should be positioned at 90 degrees to the cap parting line.

- 6) Slide the Indicator and Cross Shaft as close as possible to pinion gear, minimizing any overhang of the Target Plate. Be sure to retract the indicator plunger shaft just enough to clear the Target Plate to prevent bending the indicator.

- 7) Make sure the indicator shaft end is seated on the target place and note the reading on the dial. Multiply the small counter number by 0.100" and add the thousandths pointer reading to get your INDICATOR READING. Subtract your INDICATOR READING from the CALIBRATED DEPTH (3.375 for the long calibration tube, 2.500 for the intermediate, & 1.900 for the short) and you will have obtained your MEASURED PINION DEPTH.

**Example:** If the reading on the indicator is 0.778" (7 complete revolutions plus reading), subtracting from 3.375 would equal 2.597". This is the MEASURED PINION DEPTH.

**NOTE:** To minimize error, rotate the pinion gear to at least four different positions and average the three most similar readings.

- 8) Compare the MEASURED PINION DEPTH to the Pinion Depth number inscribed on the pinion gear or obtained from the O.E.M. Gear Section to determine the amount of shims to be added or removed.

**FIGURE 3: Pinion Checker Set-Up**

GM 10 & 12 Bolt, Dana 60, Chrysler 8 3/4"

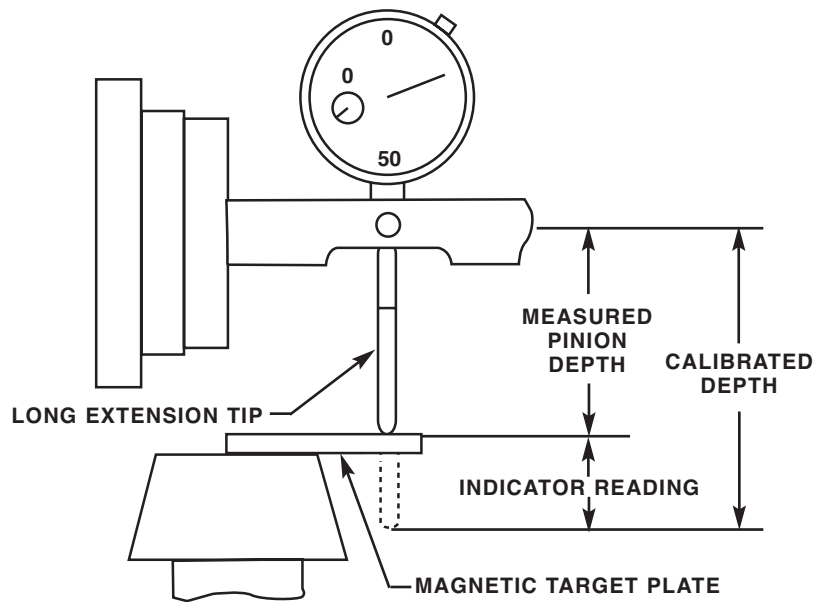

**FIGURE 3 (continued): Pinion Checker Set-Up**

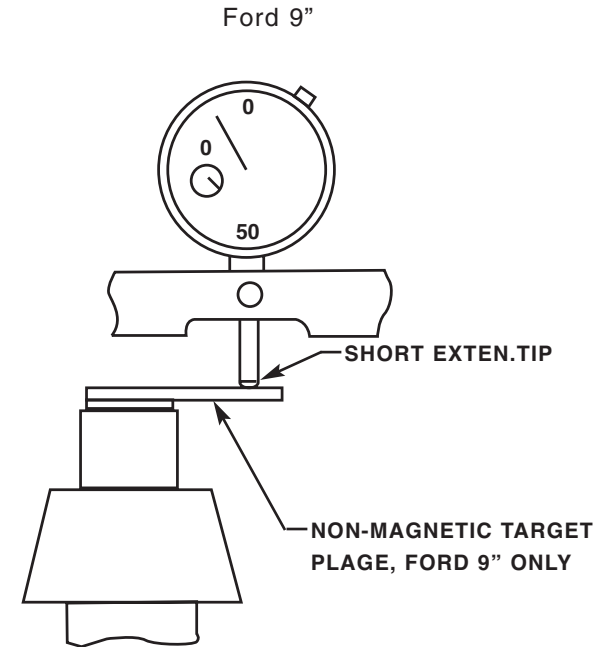

GM 8.2" 10 Bolt, Ford 8.8"

